

Re-Configurable Airplane Mission Trainer

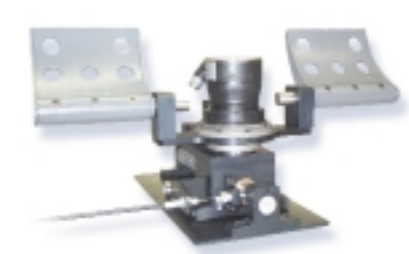

- Power ————
- CAN Bus ————
- Force Sensor ————
- RS232 ————
- Ethernet ————

WITTENSTEIN

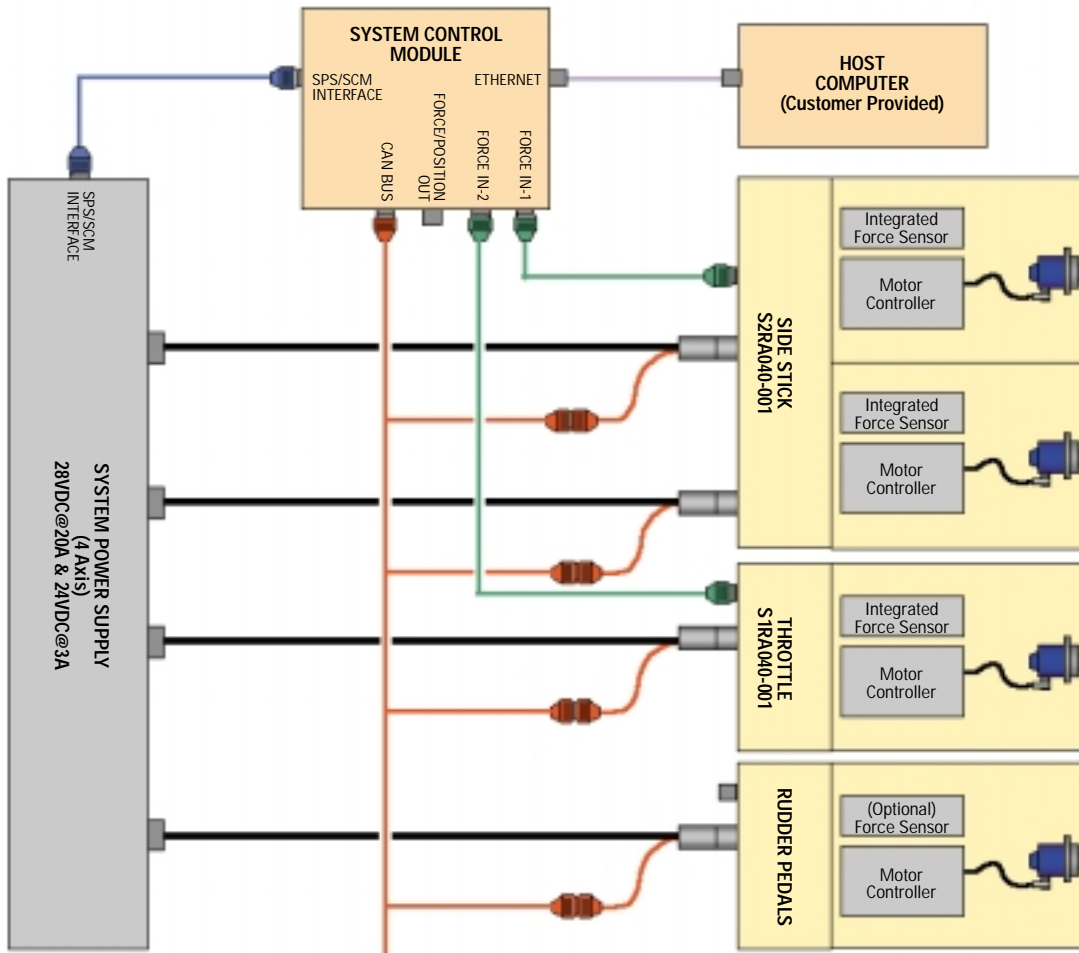

aerospace & simulation

www.wittenstein.aero

Company Profile

Wittenstein Aerospace & Simulation, a part of WITTENSTEIN AG, is a world leader in design, development and production of control loader technology for the aerospace and simulation markets. WITTENSTEIN AG is a market leader in the design, development and production of high precision planetary gear reducers, rotary and linear servo actuators and complete drive systems. The company has more than 700 employees and annual turnover of over \$100 million, of which 42% is from export sales. Our products can be found in the aerospace, robotics, medical, packaging and process control industries. WITTENSTEIN AG has 9 foreign subsidiaries and a network of 50 agencies worldwide, thus ensuring on the spot service and support, as well as having a 24-hour customer care hotline.

Wittenstein Aerospace & Simulation strives to produce cutting edge electric control loading technology by implementing the IMI strategy of Integration, Miniaturization and Intelligence. The electro-mechanical servo systems offer a reduced size and weight that is unique to this industry. No other company can offer such innovative, high quality and highly reliable electric control loading solutions in the same package.

Wittenstein Aerospace & Simulation offers complete solutions for our customers. The control loader systems are based on an integrated, high performance servo motor and planetary gearbox using the latest in helical gear technology, state of the art integrated control electronics, and our own proprietary software that provides programmable force-feel characteristics. These units are modular in form, so the user can select the servo, gear ratio, mechanical gimbals and system control module configuration to suit the application. The high performance and programmability of the control loader systems make them equally suitable for both trainer applications and high fidelity simulator systems alike.

WITTENSTEIN AG has a strong culture of new product development that has contributed to its impressive rate of growth over the last fifteen years. Over 85 percent of turnover comes from products that are less than 5 years old. Approximately 12 percent of the employees work in the research and development department. All profits are re-invested in the development of new products, manufacturing, systems, and processes as well as the further education of its employees.



Manfred WITTENSTEIN, the president and owner, is very active in the running of the WITTENSTEIN AG. It is his drive that has been instrumental in WITTENSTEIN AG being voted in the top 100 companies of the German State of Baden Wuerttemberg, along with world famous companies such as Daimler-Chrysler and Porsche. This ranking recognizes the company's innovative product strategy, customer orientation and the high quality of its products and staff.

WITTENSTEIN



aerospace & simulation

Sales Office Europe & ROTW

WITTENSTEIN aerospace & simulation GmbH
Walter-Wittenstein-Strasse - 97999 Igersheim, Germany
Phone: +49 (0)7931 493-0 • Fax: +49 (0)7931 493-9 09

Sales Office North America

WITTENSTEIN aerospace & simulation Inc.
931 S. Semoran Blvd., Suite 202 • Winter Park, FL 32792 USA
Phone: (407) 672.0010 • Fax: (407) 672.0301

www.wittenstein.aero • email: info@wittenstein.aero