

# Modular Control Loaders

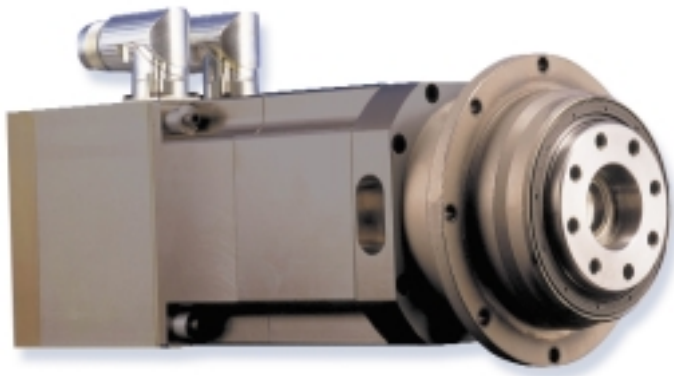

## **Unique Features**

- *Both compact and light*
- *Smooth, precise and repeatable feel*
- *Proven WITTENSTEIN motors, gearboxes and digital motor controllers*
- *Mechanically simple and easy to mount*
- *Robust and reliable*
- *Latest integrated digital motor control technology*
- *Force loop closed in motor controller*
- *Direct control from the host simulation system via a CAN bus link*
- *Stand-alone system control module with multi-axis control loader software for complete system applications*

## **Wittenstein Aerospace & Simulation**

The Aerospace and Simulation Division has developed a range of Control Loaders based on our standard integrated motor gearboxes that provides programmable feel characteristics. The units are available in a modular form so that users can select the servo system, mechanical gimbal and system control module configuration to suit their application. Their high efficiency and ability to be back-driven means that users can choose to dispense with force sensing and feedback for lower cost applications. The high performance and programmability of the systems make them suitable for both mission trainer applications as well as high fidelity loaders.

Wide range of applications:

- Airplane and helicopter simulators and FTD's
- Mission trainers for airplanes and helicopters
- Land vehicle simulators
- Military vehicle simulators
- Steering wheels

## **Operation of the System**

High dynamic performance brushless ac motors with low cogging are used to drive the control loader through a two-stage planetary precision gearbox. The motor has a digital motor controller integrated in the motor housing that determines the torque, speed and position of the associated axis. A force transducer mounted on the output flange feeds the force signal back to the motor controller. A system control module controls the force-feel characteristics so that units can be re-configured or dynamically changed to inject advanced cues and simulate different systems or changing operating conditions. Alternatively, the user can implement a force command system direct from their host using the CAN bus interface.

Units are extremely easy to install. The compact design allows mounting arrangements that are close to the stick base, eliminating the need for extensive control rods and links. Integration is simplified by the use of CAN bus serial bus technology to couple twin control loaders to a system control module.

## **Aerospace and Simulation Division**

We specialize in the application of active force-feel technology. All related technologies are in-house, enabling us to apply our many years of experience to your electric drive system application.

**WITTENSTEIN**



**aerospace & simulation**

[www.wittenstein.aero](http://www.wittenstein.aero)

# Technical Information

The Aerospace and Simulation Division MYTA series of servo drive motor systems incorporates digital motor control electronics with a CAN bus interface and an integrated motor gearbox. The robust output bearing is able to carry large tilting moments and axial forces, thus reducing support requirements for overhanging loads.

The high precision two-stage planetary gearboxes, with low backlash, have exceptional high efficiency, low friction and are smooth running. High performance, low cogging, brushless ac motors have an intelligent digital controller that provides position, velocity and torque control loops as required.

The force loop can be closed over the motor controller digitally. The MYTA servos come with alternative gear ratios. The control loader can be supplied with either resolver or encoder, depending on fidelity requirements.

## Torque Capability

		CL004 MYTB004	CL010 MYTB010	CL025 MYTB025
28 Vdc	Tmax	45 Nm (400 lb.in) @ 13rpm	100 Nm (885 lb.in) @ 15rpm	250 Nm (2212 lb.in) @ 13rpm
	T cont stall	22 Nm (195 lb.in) @ 27rpm	55 Nm (486 lb.in) @ 20rpm	120 Nm (1062 lb.in) @ 20rpm
42 Vdc	Tmax	45 Nm (400 lb.in) @ 13rpm	150 Nm (1327 lb.in) @ 60rpm	300 Nm (2655 lb.in) @ 37rpm
	T cont stall	22 Nm (195 lb.in) @ 27rpm	60 Nm (531 lb.in) @ 70rpm	110 Nm (973 lb.in) @ 60rpm

Standard gear ratio  $i = 43$

## SYSTEM CONTROL MODULE

### Features

- Multiple stick control capability with pilot/copilot electronic coupling
- CAN bus interface to stick servo units
- Ethernet, RS232 or customized interfaces to host
- Multiple aircraft characteristics defined in configuration files

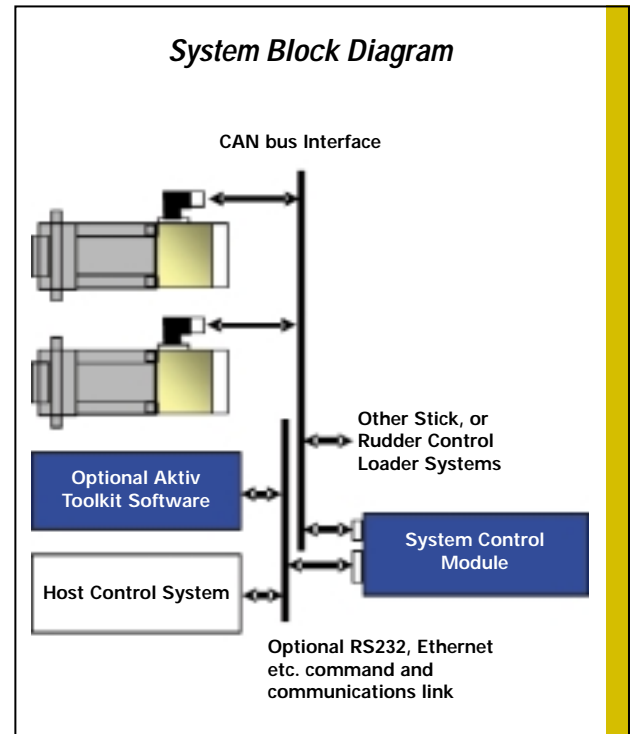

### Size

- Six-slot microbox  
177 mm (7 in), 274 mm (10.8 in), 287 mm (11.3 in) H, W, D
- 19 inch rack mountable  
177 mm (7 in), 432 mm (17 in), 457 mm (18 in) H, W, D

### Customer Options

- Analog outputs of stick parameters
- Software toolkit for setting defaults and system evaluation
- Setup of characteristics to meet customer requirements

**WITTENSTEIN**



**aerospace & simulation**

### Sales Office Europe & ROTW

WITTENSTEIN aerospace & simulation GmbH  
Walter-Wittenstein-Strasse - 97999 Igersheim, Germany  
Phone: +49 (0)7931 493-0 • Fax: +49 (0)7931 493-9 09

### Sales Office North America

WITTENSTEIN aerospace & simulation Inc.  
931 S. Semoran Blvd., Suite 202 • Winter Park, FL 32792 USA  
Phone: (407) 672.0010 • Fax: (407) 672.0301

www.wittenstein.aero • email: info@wittenstein.aero