

Re-Configurable Yoke Control Loader



Unique Features

- Both compact and light
- Smooth, precise and repeatable feel
- Proven WITTENSTEIN motors, gearboxes and digital motor controllers
- Mechanically simple and easy to mount
- Robust and reliable
- Latest integrated digital motor control technology
- CAN bus to link control loader to system control module

Wittenstein Aerospace & Simulation

The Aerospace and Simulation Division has developed a re-configurable yoke control loader that provides programmable feel characteristics for low cost light aircraft simulators. Its high performance and programmability make it easily re-configurable to suit different aircraft configurations. Feel characteristics can be changed by simple commands from the host. The system is qualified for JAA FNPT II applications.

Operation of the System

High dynamic performance brushless ac motors are used to drive the yoke through single or two stage planetary precision gearboxes. The motor has a digital motor controller that determines the torque, speed and position of the axis of rotation. This enables the system control module to control a force-feel characteristic at the yoke. They can be re-configured or dynamically changed to simulate different aircraft or changing operating conditions.

They are extremely compact and easy to install. Integration is simplified by the use of CAN bus serial bus technology to couple yoke and rudder pedals to system control module. A system control module is used to control the yoke. For multiple stick, throttle and rudder pedal applications, units can be linked to one system control module using a CAN bus cable for both implementing and coordinating control.

The unique mechanical design of the unit, that is both compact and very light, has been achieved by using the low backlash, low friction, motor-gearboxes developed by the WITTENSTEIN Group for applications such as robotics and manipulators.

Aerospace and Simulation Division

The Aerospace and Simulation Division specializes in the application of active force-feel technology. We offer the advantage of having all related technologies in-house. This enables us to react quickly to market needs as we can take standard products and adapt them to the needs of the application. WITTENSTEIN's many years of experience as a supplier of gearboxes, ac brushless motors, integrated motor-gearboxes, and digital motor controllers, provides us with a unique experience in the field of electric drive systems. This know-how has been incorporated into our yoke control loader products.

WITTENSTEIN



aerospace & simulation

www.wittenstein.aero

Technical Information

CONTROL LOADING UNIT

Force, Speed & Travel Capability

Parameter	Pitch	Roll
Cont. force	150 N (33 lbf)	5.6 Nm (144 in-lb.)
Peak Force	390 N (85 lbf)	15.0 Nm (215 in-lb.)
Travel	± 6 cm (±2.4 in)	± 50°
Max Speed	100 m/s	360°/sec

Size

426 mm (16.8 in), 240 mm (9.5 in), 98mm (3.9 in) H,W,D

Dynamically Variable Characteristics

- Force-feel curve
- Software hard & soft stops
- Trimming
- Centering features
- Shaker
- Dynamic response

SYSTEM CONTROL MODULE

Features

- Multiple stick control capability with pilot/copilot electronic coupling
- CAN bus interface to stick servo units
- Ethernet, RS232 or customized interfaces to host
- Multiple aircraft characteristics defined in configuration files

Size:

- Six-slot microbox
177 mm (7 in), 274 mm (10.8 in), 287 mm (11.3 in) H, W, D
- 19 inch rack mountable
177 mm (7 in), 432 mm (17 in), 457 mm (18 in) H, W, D

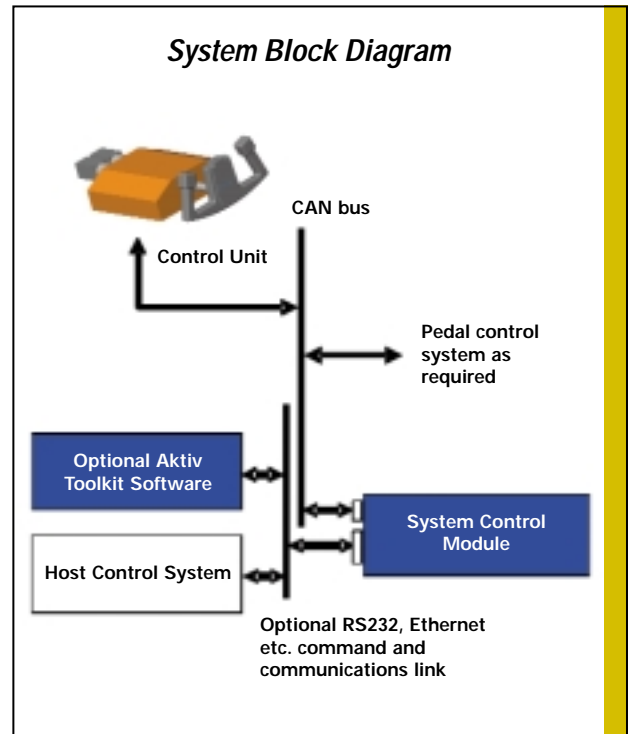

Customer Options

- Analog outputs of control parameters
- Software toolkit for setting defaults and system evaluation
- Setup of characteristics to meet customer requirements

WITTENSTEIN



aerospace & simulation

Sales Office Europe & ROTW

WITTENSTEIN motion control, aerospace & simulation division
Walter-Wittenstein-Strasse - 97999 Igersheim, Germany
Phone: +49 (0)7931 4930 • Fax: +49 (0)7931 4939 09

Sales Office North America

WITTENSTEIN solutions inc.
931 S. Semoran Blvd., Suite 202 • Winter Park, FL 32792 USA
Phone: (407) 672.0010 • Fax: (407) 672.0301

www.wittenstein.aero • email: info@wittenstein.aero